



Durable Mechanism

Fast Passage

Elegant Design

Aesthetic Solution

User-friendly

Longlived

T 350 HG 60 CHUBBY

HG GATE

T 350 HG 60 CHUBBY

HG GATE

T 350 HG 60 Chubby provides an aesthetic solution to the access control needs with its economical dimensions and stylish design. Thus, space safety can be complemented by a modern look.

Application

T 350 HG 60 Chubby can be used easily in hotels, universities, business centers, ministries, banks, airports and any similar areas especially in buildings that value interior design.

Basic Materials

T 350 HG 60 Chubby is produced in AISI 304 stainless steel body, with reinforced 12 mm tempered glass wings and 10 mm plexyglass top cover. Logo can be applied on glass wings. If desired, glass wings can be produced from pvc material. All mechanical parts are specially coated to protect against corrosion. The electronic boards are designed by the qualified engineers of Makim, enabling T 350 HG 60 Chubby operate in various modes and entegrations.

General Use

All kind of access control systems like card reader, biometric reader, remote control unit or push button can be entegrated to T 350 HG 60 Chubby. For this purpose, optional reader foot can be produced by Makim. Once the access right is granted, the gate will open automatically and once the passage is completed, the gate closes itself. If the user does not use the passage right in 15 seconds, the gate will give buzzer warning and it will be closed again. Unauthorized passages are prevented via special sensors. The passage interval is 90 cm. There are LED lights on both sides of the T 350 HG 60 Chubby with green and red color indicating the access direction.

Safety

Optional production can be done to provide manual or automatic opening of the wings in case of power cut. As an alternative, battery can be used , in order to keep T 350 HG 60 Chubby working in its standard mode for a certain period while power is gone.

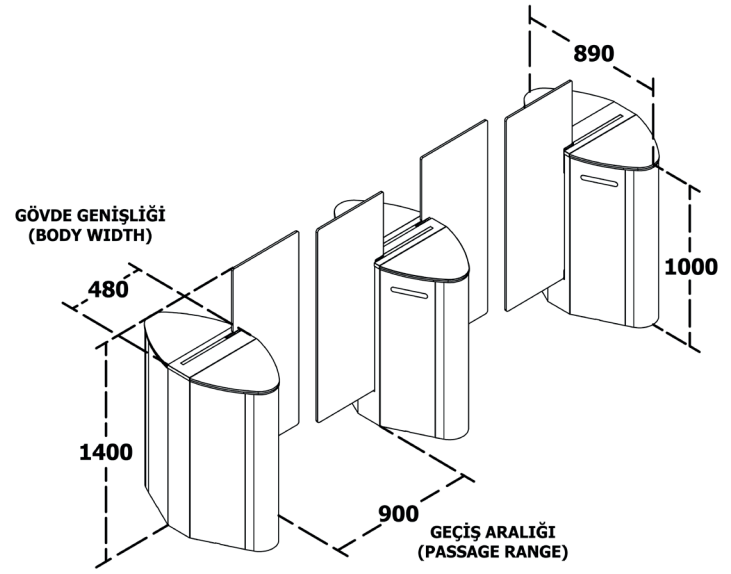

Control /Operation Voltage	100-230 VAC 50/60 Hz
Power Consumption	58 W
Operation Temperature	- 20° C - + 70° C
Passage Speed	20-30 P / Minute
Opening/Closing Period	0,50 - 0,70
Passage Range	Max. 900 mm
Weight	75 Kg
Usage Area	Indoor
Body	304 Grade SS
Top Cover	10 mm Plexyglass
Wings	12 mm Tempered Glass / op. 12 mm plexyglass
Optional Accessories	Biometric reader, card reader, button, remote control, counter, automatic opening relay
Protection	IP 42
Security Level	●●●○○

FACTORY

Address: Sincan Organize Sanayi Bölgesi, Erkunt Cd. No: 20 06930 Sincan / Ankara
Phone: +90 (312) 267 56 87 Fax: 0 (312) 267 56 99
satis@makim.com.tr

ANKARA SALES OFFICE

Address: Batı Sitesi Mah. Gersan, 2307 Sk/3.Cad. No:16 06970 Ergazi / Ankara
Phone: +90 (312) 257 02 52 Fax: 0 (312) 257 02 55
pazarlama@makim.com.tr

BRANCH

Address: Perpa Ticaret Merkezi, B Blok Kat: 7-8 No: 987-989 Şişli İstanbul
Phone: +90 (212) 210 29 41 Fax 0 (212) 210 68 15
sube@makim.com.tr

WAREHOUSE AND TECHNICAL DELIVERY

Address: Perpa Ticaret Merkezi, B Blok Kat: 1-2 No:57 Şişli İstanbul
Phone: +90 (212) 210 29 41 Fax: 0 (212) 210 68 15
sube@makim.com.tr